

ND32 ATCO™ Airline Flanged Ball Valve - AF3X

MAINTENANCE 1/2

Item	Designation	Part Number Standard
Ball seals kit		
10	Ball seal (PTFE)	11 91 09 00 00
12	Main seal (PTFE)	
High temp° ball seals kit		
workingT°: -40° to +250°C		
10	Ball seal (PTFE/Graphite)	on request
12	Main seal (PTFE/Graphite)	
Ball kit		
11	Ball (316)	11 14 01 94 00
Handle kit		
1	Screw M6x16 (304)	11 14 02 91 00
2	Washer W6 (304L)	
3	Handle (304L)	
4	Bearing (PTFE)	
5	O'ring (Viton)	
6	Spacer (PTFE)	
7	O'ring (FEP/Silicon)	
8	Spindle seal	
9	Spindle	
Spindle		
9		11 14 02 00 02
Spindle seals kit		
4	Bearing (PTFE)	11 14 01 92 00
5	O'ring (Viton)	
6	Spacer (PTFE)	
7	O'ring (FEP/Silicon)	
8	Spindle seal	
Filter kit		
13	Filter (316L)	11 14 01 95 00
14	Elastic ring (304L)	
Remote control handle kit		
C	Remote control handle	11 14 15 94 00
Tools kit		
A	Spindle stop tool (2017)	11 14 01 90 00
B	Spindle seal tool (304L)	

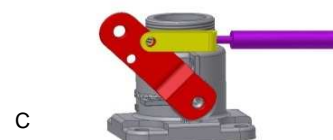
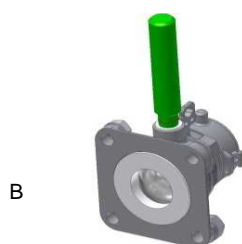
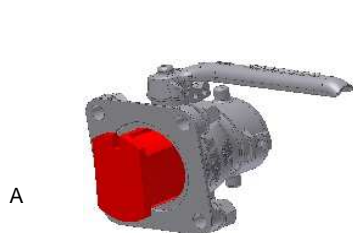
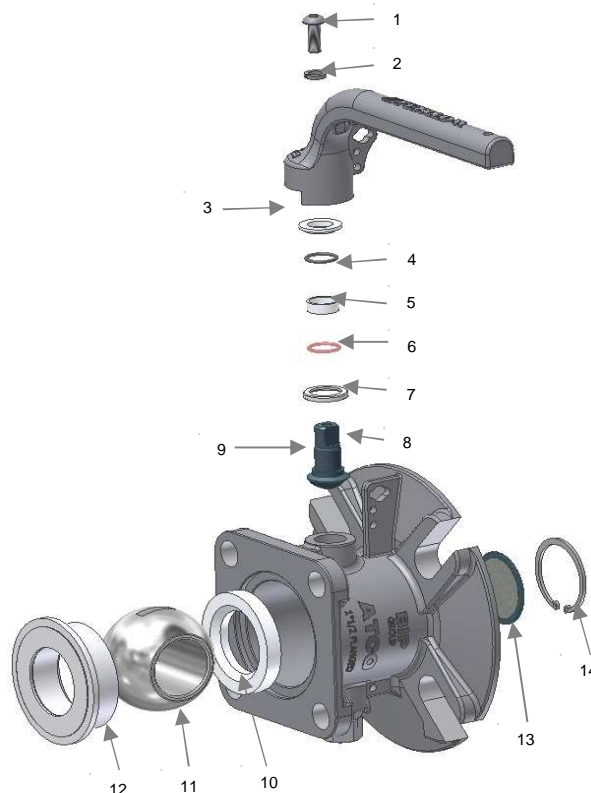

Nb: Perolo recommends that the spindle seals are changed simultaneously with the spindle to ensure that the ball valve remains clean and water resistant and tight.

ND32 ATCOTM Airline Flanged Ball Valve - AF3X

MAINTENANCE 2/2

We recommend you to service the airline every 2.5 or 3 years. The first process must always be to remove the Airline valve from the tank.

CAUTION: Before an airline valve is removed, the cap must be removed and the valve opened carefully, with the operator face as far away from the valve as possible (out of line with venting area) in case the tank is still pressurized.

Remove the valve to a workshop with a clean working area on the work bench.

Strip Valve by first removing circlip from top to remove gauze (if fitted). Then remove main base seal by half opening ball valve and pulling seal with fingers.

With base seal removed, rotate handle to closed position in order to remove ball. Upper seal can now be removed by pushing seal down with finger (or blunt tool) inserted through valve outlet.

To replace spindle seals, first remove M6 bolt securing the handle. Remove handle and press spindle back into valve body. Remove old seals taking care not to damage the valve body.

Assembly

Please refer to the ND32 ATCO Airline threaded ball valve maintenance sheet (AD3X).

Same assembly steps.