

# 3" pneumatical "CHEMFLOW" footvalve with side actuator

## Installation sheet

### INSTALLATION

Store "CHEMFLOW" safety footvalve original packaging safe from dust and chocks.  
The leak proof face of the connection is machined with a rounded bottom spiral groove (stock finish).  
The mounting flange must be machined in identical or similar fashion.

### ASSEMBLY

Make sure no dirt or grit has remained on the receiving flange and gasket.  
Screw the studs into the tank container flange (to the shortest threading side).  
Be careful in respecting the longest studs positioning in **1** and **2**.  
Ensure that the three flanges are out of defects, and then fit the PTFE envelope gasket.  
Fit the "CHEMFLOW" footvalve in position and, start to screw the nuts onto the studs **1** and **2**.  
Tighten then the studs and nuts symmetrically with a maximum torque of 5 daN.m

1. Screw the studs into the tank container flange (to the shortest threading side). Be careful in respecting the longest studs positioning in **1** and **2**.
2. Ensure that the tank weld in pad, and the two other foot valve flanges are out of defects, and then fit the synthetic fiber / PTFE envelope gasket.
3. Fit the "CHEMFLOW" footvalve in position and, start to screw the nuts onto the studs **1** and **2**.
4. Tighten then the studs and nuts symmetrically with a maximum torque of 5 daN.m.

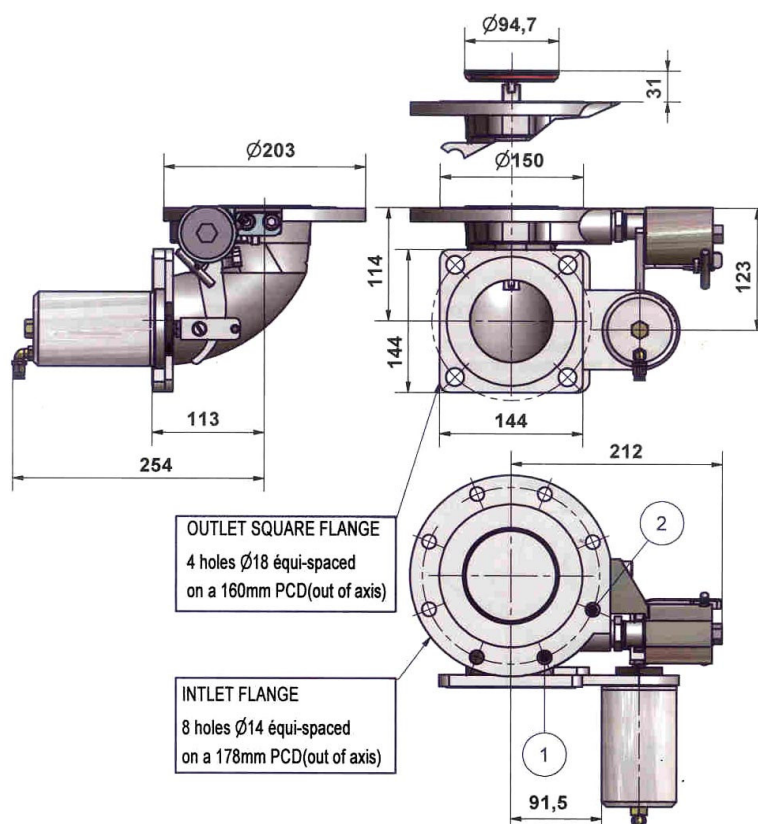

### ACCESSORIES

Description	PART N°
Emergency spanner	17.11.01.90.00
Tank weld in flange	12.91.18.00.00
Outlet flange gasket	12.91.39.00.00
Screw set	17.11.03.92.00
Inlet flange gasket	12.91.20.00.00
Heated flange	11.90.32.00.00

