

12" "MULTIDO"™ manlid low profile and standard

Installation sheet

INSTALLATION

- Carrefully weld the manlid on the tank to avoid neckring seal face distorsion
- Check the neckring is clean (no weld spits)
- When tightening bolts are delivered separately check the stop washer is installed under the screw head on every bolt

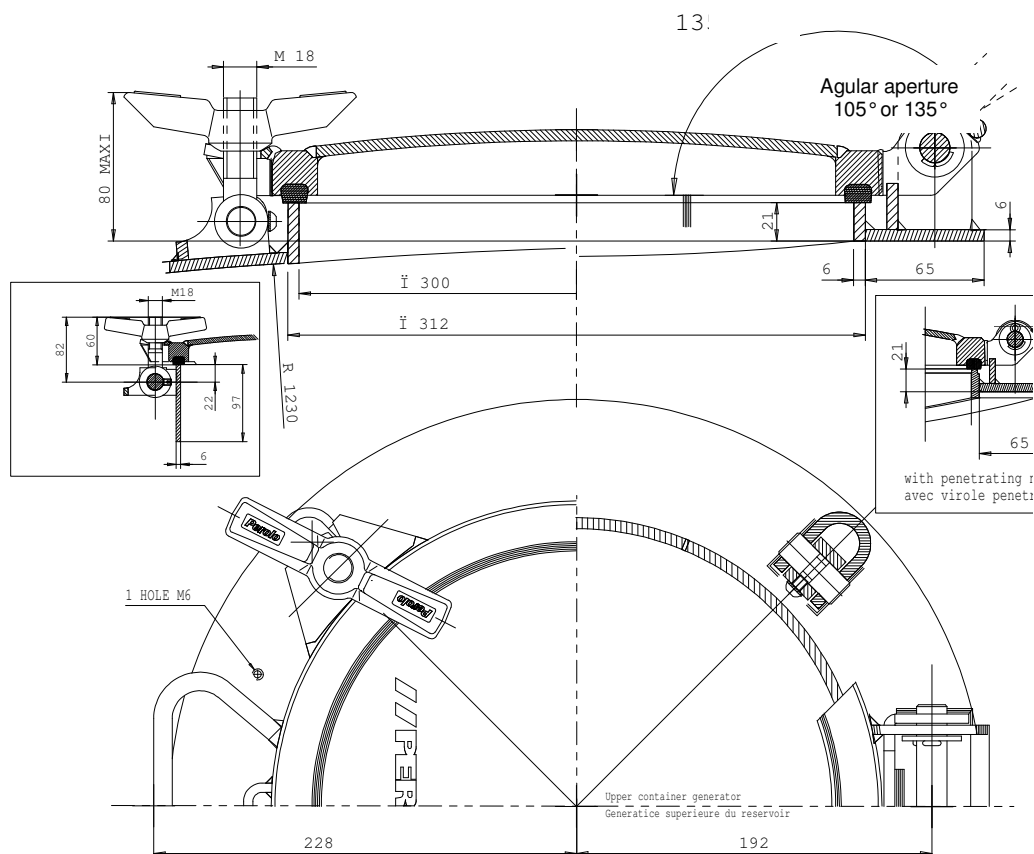

ACCESSORIES

See specification sheet SEALS MANLID" ref. PWA1113750000