

# 20" "MULTIDO"™ manlid special for transport of hydrogen peroxyde

## Installation sheet

### INSTALLATION

- Carrefully weld the manlid on the tank to avoid neckring seal face distorsion
- Check the neckring is clean (no weld spits)
- When tightening bolts are delivered separately check the stop washer is installed under the screw head on every bolt

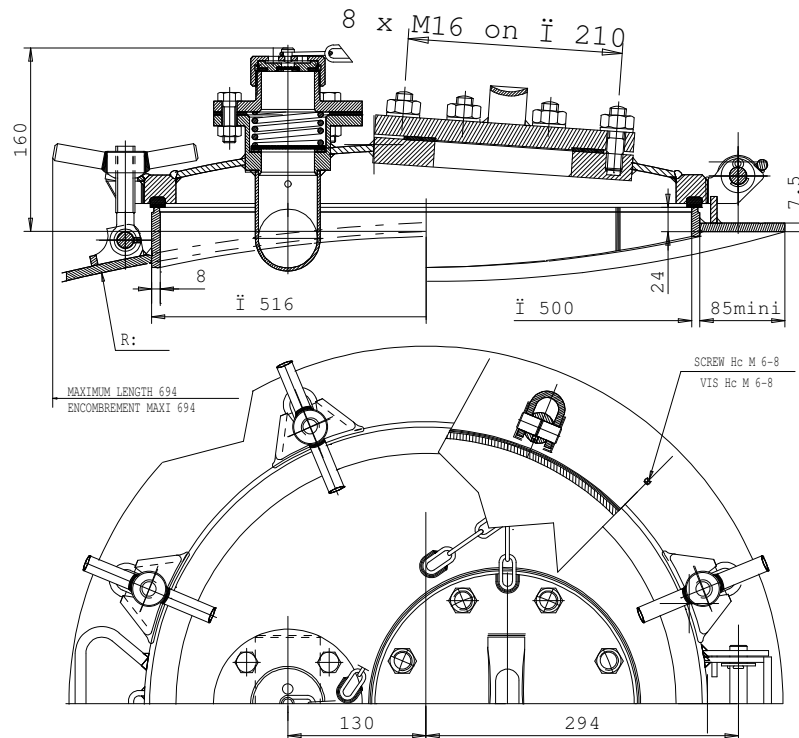

### ACCESSORIES

ITEM ORDERED SEPARATELY		
①	80 12 53 05 00 10	Bursting disc (pressure 4,5 bar at 60°) or other pressure on request
ASSEMBLY FOR 10" BURSTING DISC		
②	Weld in flange & surge protection plate	
③	upper flange & protection cowl	
④	Bolting kit	
<input type="checkbox"/>	Personnal marking	
<input type="checkbox"/>	Seal ring	

