



ND300 MULTIDO manlid : A wide range to suit tank containers, road tankers and storage tanks intended for chemical and foodstuff liquid products.

SPECIFICATION	
Nominal diameter	300 mm (12")
Weight	15 Kg for 21mm Neckring
Fastening points	4
Working Pressure	3 Bar or 4 Bar
Test Pressure	4,5 Bar or 6 Bar
Working Temperature	-40° to + 200°C

Temperature range may vary according to the seal material

CONFORMITY, CERTIFICATION & APPROVAL	
ADR / RID / IMDG / ASME / EN14025/ PED compliant on request	
Lloyd's Register and Bureau Veritas	

ACCESSORIES	
Coverlid seal EPDM/PTFE	11 13 75 00 20
Swingbolt ass. (58mm)	12 93 86 92 00
Swingbolt ass. (83mm)	12 93 86 91 00
Hinge kit	12 13 68 91 00
4 points low profile coverlid no TIR (316L)	CMS354D4SS
4 points standard coverlid no TIR (316L)	CMS354D4DS

STANDARD FEATURES (See Codification for option)	
Made of (material)	316L / 1.4404 stainless steel manlid
Seal material	seal not included
Neckring height	from 21 to 200 mm - Other on request
Neckring thickness	6 mm - Other on request
Fastening	Swingbolts with captive wing nuts
Perfect tightness	Trapezoidal seal groove - Seal 14x14

**DIMENSIONAL DRAWING**

Low profile : neckring ≤ 40 mm  
 Standard profile : neckring > 40 mm

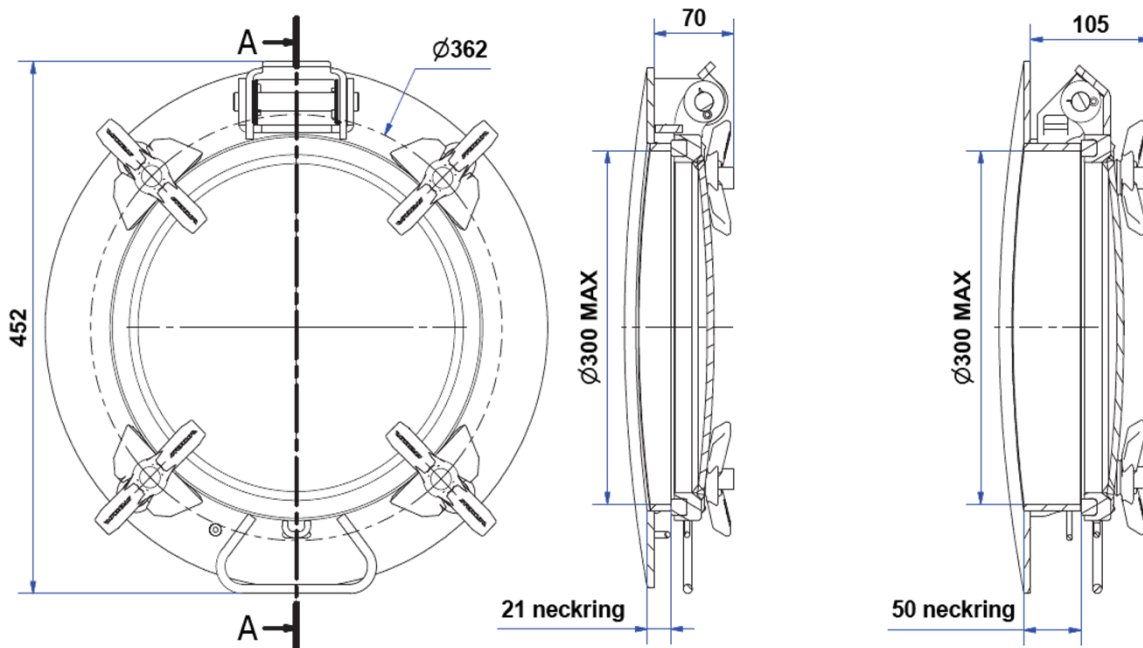

### CODIFICATION

STANDARD PART NUMBER

M S 3 4 D 4 6 F 0 F 20 T B 5

YOUR PART NUMBER

M 3 4 0

#### MATERIAL

St.st 904L	U	St.st 316L	S
St.st Duplex	D	St.st 304L	Y
		C.st P355NL	P

#### INTERNAL DIAMETER

300mm internal diameter	3
-------------------------	---

#### MAWP

4 Bar (test pressure 6 bar)	4
3 Bar (test pressure 4,5 bar)	3

#### FINISHING - other on request

No surface treatment	B
Acid etched	D
Electropolished	P

#### FASTENING POINTS

4 fastening points	4
--------------------	---

#### NECKRING THICKNESS

8 mm	8	6 mm	6
------	---	------	---

#### NECKRING HEIGHT - other on request

21 mm (low profile)	F
24 mm (low profile)	A
58 mm (standard)	E
97 mm (standard)	D
150 mm (standard)	I

#### PROTUSION HEIGHT

No protusion	0
--------------	---

#### COMPENSATED NECKRING-oth. on request

No compensated neckring	E
70 mm width & 6 mm thick	F
85 mm width & 8 mm thick	G

#### COMP. NECKRING RADIUS-oth. on request

2nd & 3rd digit eg: radius 1 <u>20</u> mm	20
No radius	XX

#### SEALING

1 sealing	S	T.I.R. sealing	T
-----------	---	----------------	---

#### SWINGBOLTS - other on request

Standard swingbolts in 304 SS - wing nut in Brass	B
Swingbolts in SS with hexagonal nuts in SS	X
Safebolt in SS - wing nut in SS	S

#### ASSEMBLY OPTIONS

fully assembl.	1	not assembled	5
----------------	---	---------------	---



**MANLID**

Due to our policy of continuous product improvement, specifications may change without notice - Specification sheet PWA 11 15 27 20 00 E

It is the customer's responsibility to check the compatibility between valves material and transported product.

PEROLO SAS, 69 Rue des Maçons, 33390 Blaye, FRANCE -Phone : + 33 (0)5 5742 67 00 - Email : sales@perolo.com