

**INSTALLATION**

To install the ND32 ATCO™, the weldin flange must be machined with stock finish (serrated surface).

1. Ensure that the Inlet (tank side) flange is clean; free from dirt and grit.
  2. Install the valve on the weldin flange, handle in closed position. **NO GASKET NEEDED**
  3. Install the 4 screws and washers.
- Tightening torque required : 30 N.m +/- 5
4. Open and close the valve 3 times before operating to install the PTFE seals.
  5. Refer to PWAGENE001 for bolt tightening sequence.

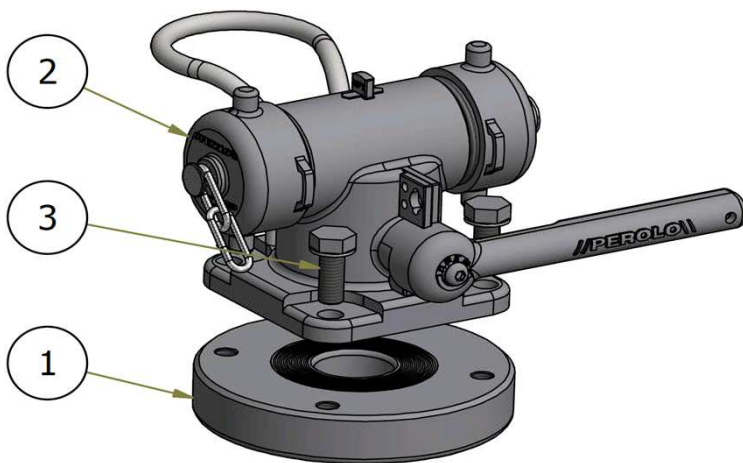

NO GASKET

ITEM	DESCRIPTION	SPECIFICATION	PART N°
2	ND32 ATCO Ball Valve	ND32 Ball Valve 4 x Ø11 x 103.5 PCD, with gauge protection	AT4X6T23CS22
3	Screw Kit	4 x M10-25 screws, 4 x grower washers	12 91 99 00 00
1	Weld-in Flange	int Ø32mm, ext Ø127mm, thickness 22mm 4 x M10 x 103.5 PCD 316L Stainless Steel	11 90 20 00 00

**if a piping system linked to the tank is installed on the process side of the valve, we recommend to have a flexible hose in-between the valve and the piping system to avoid any additional stress on the fastening studs**

