

INSTALLATION

To install the ND50 ATCO<sup>TM</sup>, the weldin flange must be machined with stock finish (serrated surface).

1. Ensure that the Inlet flange and gasket are clean; free from dirt and grit.
2. Screw the studs from kit 11 91 13 91 00 on the weld in flange (1).
3. Place the gasket (2) on top of the weld in flange.
4. Fit ball valve and secure with washers and nuts.

The required tightening torque is 50 N.m +/-5 for A2/A4 - 70 bolting class

5. Cross type serration
- 6- Check torque after 24 hours & tighten at 50 Nm if required
- 7 - Lubrilate the threads (PTFE grease or MOS2)
8. Refer to PWAGENE001 for bolt tightening sequence.

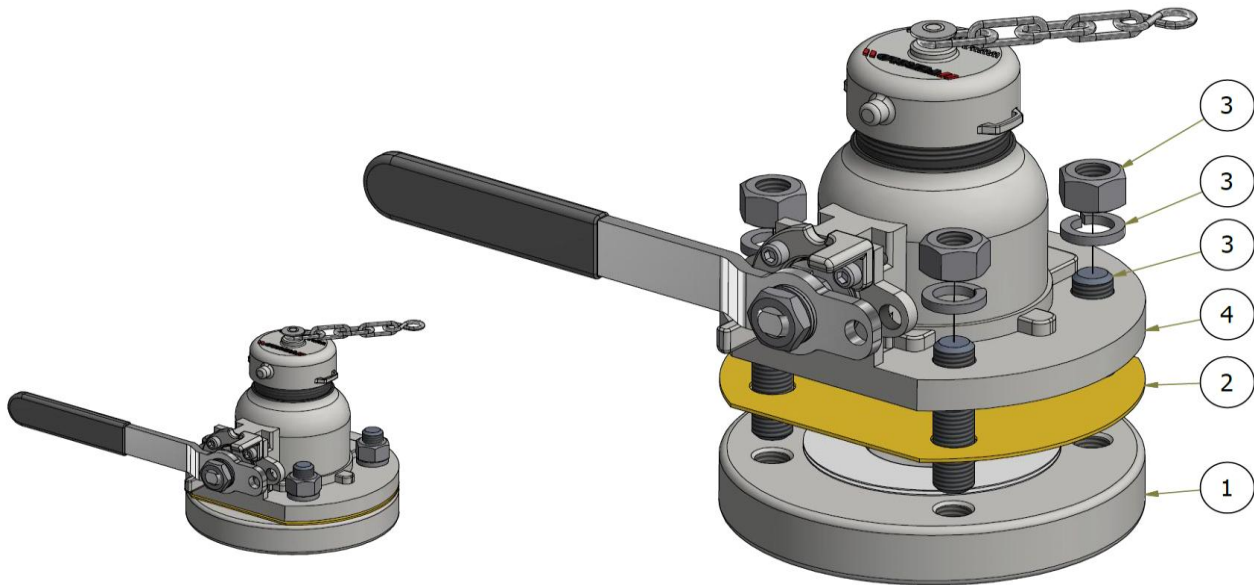

ITEM	DESCRIPTION	SPECIFICATION	PART N°
4	ND50 ATCO Ball Valve	PN 16 Full Bore, 316 L stainless steel Inlet flange 4xø17x125PCD Outlet flange 2" BSP	AD5X16T1BCS00
3	Bolting Kit	4 x M16 50 studs, 4 x M16 nuts and 4 x grower washers class 70	17 12 12 96 00
2	Gasket	ext ø 165mm, int ø 50mm 4xø18x minimum 125PCD CNAF/PTFE - thickness 2mm	11 90 29 00 00
1	Weld-in flange	ext ø 165mm, int ø 50mm, thickness 21mm 4xM16x125PCD 316L stainless steel	11 90 25 00 00

**if a piping system linked to the tank is installed on the process side of the valve, we recommend to have a flexible hose in-between the valve and the piping system to avoid any additional stress on the fastening studs**

Due to our policy of continuous product improvement, specifications may change without notice - Installation sheet PWA 11 14 61 30 00 D

Perolo warranty is null and void in case of fitting non OEMparts

It is the customer's responsibility to check the compatibility between valves material and transported product.

PEROLO SAS, 69 Rue des Maçons, 33390 Blaye, FRANCE -Phone : + 33 (0)5 5742 67 00 - Email : sales@perolo.com

