

MAINTENANCE

ITEM	QTY	DESIGNATION	PART N°	
			Standard	High Temp
Ball seals kit:			11 12 42 92 00	on request
10	2	Ball Seals (PTFE or PEEK)	11 12 39 00 09	11 12 39 00 28
12	1	O'Ring (FEP (or PFA for HT))	70 10 15 00 10	70 10 17 00 40
13	1	O'Ring (Viton (or PFA for HT))	70 10 01 02 39	70 10 17 00 40
11	1	Ball (316)	11 12 42 00 11	
Handle kit:			11 14 16 92 00	
17	1	Handle (st st)	-	
	1	Handle cap, nitrile	-	
3	2	M16 Nut	-	
2	1	Stop washer	-	
18	1	Washer Nordlock Ø 16	-	
Spindle seals kit:			11 12 42 93 00	
6	1	Bearing Bush (PTFE)	11 12 39 00 14	
7	1	O'Ring (FEP/silicone)	70 10 15 00 12	
8	1	Spindle Gasket	11 12 39 00 21	
Spindle kit:			11 14 16 91 00	
9	1	Spindle (St st)	11 12 39 00 16	
4	2	Elastic washer (St st)	-	
5	1	Washer (St st)	-	
3	2	M16 Nut	-	
2	1	Stop washer	-	
18	1	Washer Nordlock Ø 16	-	

Nb Perolo recommends :

- The spindle seals should be changed simultaneously to maintain the ball valve spindle perfectly tight.
- Both ball gaskets should be changed
- Valve should be in closed position during installation

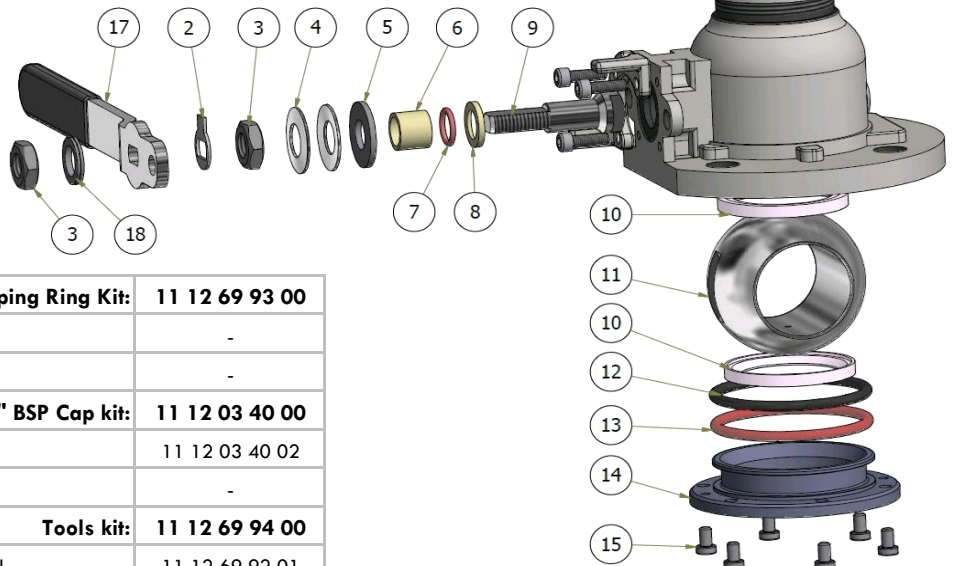

Clamping Ring Kit:			11 12 69 93 00
15	6	TBHC Screw	-
14	1	Clamping Ring (St st)	-
2" BSP Cap kit:			11 12 03 40 00
-	1	Cap Seal	11 12 03 40 02
-	1	BSP Cap & Chain	-
Tools kit:			11 12 69 94 00
A	1	Spindle Assembly tool	11 12 69 92 01
B	1	O'Ring Assembly tool	11 12 69 92 02

Due to our policy of continuous product improvement, specifications may change without notice - Maintenance sheet PWA 11 14 61 40 00 D

Perolo warranty is null and void in case of fitting non OEM parts

It is the customer's responsibility to check the compatibility between valves material and transported product.

PEROLO SAS, 69 Rue des Maçons, 33390 Blaye, FRANCE - Phone : + 33 (0)5 5742 67 00 - Email : sales@perolo.com

