

INSTALLATION

1. Check Inlet (tank side) flange is clean, free from dirt and grit. The valve must be fully open or closed.
2. Screw the studs into the weldin flange, lubricate with PTFE added grease before installing the studs
3. Install the valve on the flange, secure with washer and nuts (refer to PWAGEN001 fort bolt tightening sequence)
4. Tighten the nuts torque : 30 N.m -0/+10
5. Open and close the valve 3 times to check the operational torque.

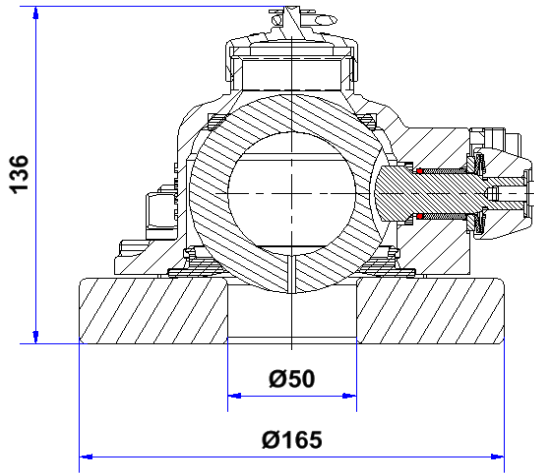

ITEM	DESCRIPTION	SPECIFICATION	PART N°
3	Bolting Kit	4 x M16 33 studs 4 x nuts and 4 x washers	11 91 13 91 00
2	ND 50 ATCO "Compact"	PN 7 Full Bore, 316 stainless steel Inlet flange 4xØ17x125PCD 2" BSP	ADC5X7T1BCS00 00
1	Weld-in flange	ext Ø 165mm, int Ø 50mm thickness 26,5mm 4xM16x125PCD 316L stainless steel	11 90 25 00 00

if a piping system linked to the tank is installed on the process side of the valve, we recommend to have a flexible hose in-between the valve and the piping system to avoid any additional stress on the fastening studs

